

# 18S430v2

Ultra Low Distortion Woofer

## Ultra low distortion series

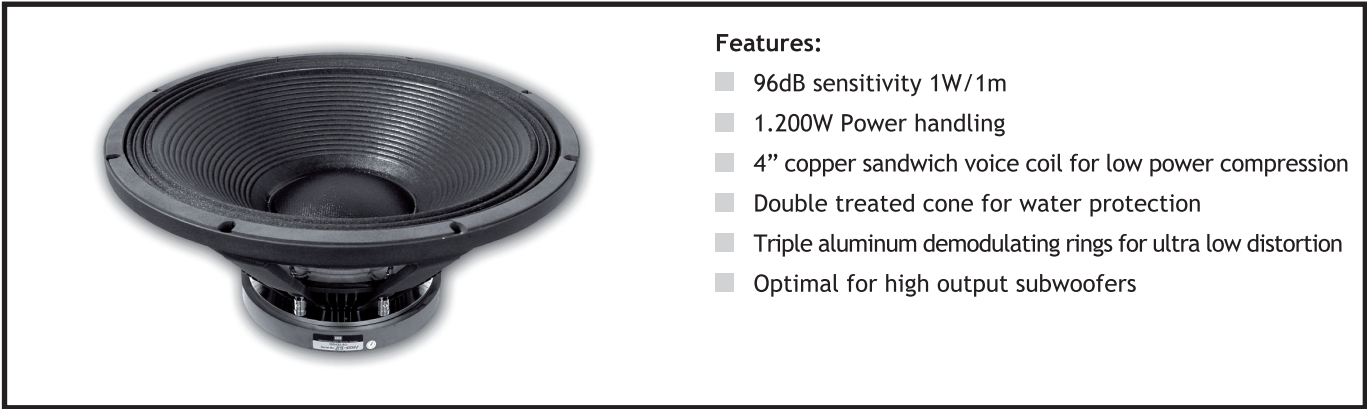

### Features:

- 96dB sensitivity 1W/1m
- 1.200W Power handling
- 4" copper sandwich voice coil for low power compression
- Double treated cone for water protection
- Triple aluminum demodulating rings for ultra low distortion
- Optimal for high output subwoofers

## SPECIFICATIONS

APPLICATION	subwoofer	
Nominal impedance	Ohm	8
Power handling AES noise	W	1200
Sensitivity ( 1W/1m )	dB	96
Frequency response	Hz	20 - 200
Voive coil diameter	mm	101.6 (4")
Voice coil material		Cu
Voice coil winding depth	mm	26
Magnet gap depth	mm	10
Basket		Cast Aluminum
Effect. diaphragm diameter D	mm	393

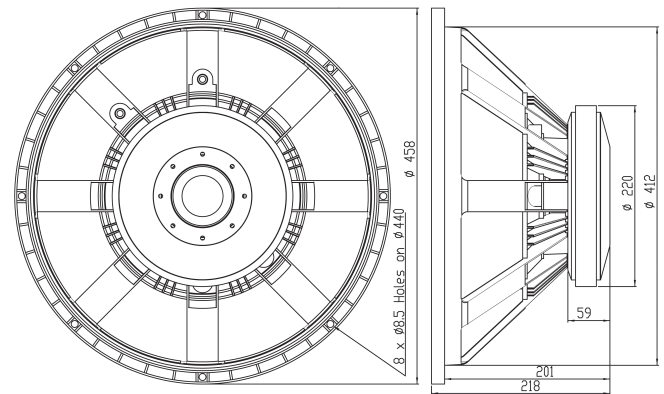

THIELE - SMALL PARAMETERS			
Resonance frequency	Fs	Hz	31
DC resistance	Re	Ohm	4.8
Mechanical Q factor	Qms		6
Electrical Q factor	Qes		0.36
Total Quality factor	Qts		0.34
Equivalent volume	Vas	L	262
Moving mass	Mms	kg	0.210
Mechanical compl.	Cms	mm/N	0.125
BL factor	BL	Tesla m	23.5
Effective piston area	Sd	m <sup>2</sup>	0.1213
Max. linear excursion	Xmax	mm	± 8
Voice coil inductance	Le1k	mH	0.82
	Le10k	mH	0.47

Frequency response measured 1000W (89.4V) at 1m in a vented enclosure of 170 litre tuned 32Hz incl. 2nd and 3rd harmonic distortion raised 10dB.

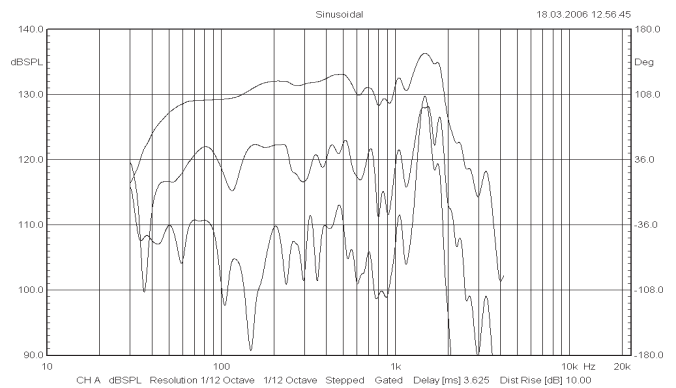

MOUNTING INFORMATION		
Overall diameter	mm	458
Mounting holes diameter	mm	8 x 8.5
Bolt circle diameter	mm	440
Baffle cut-out diameter	mm	414
Overall depth	mm	218
Net weight	kg	12.8

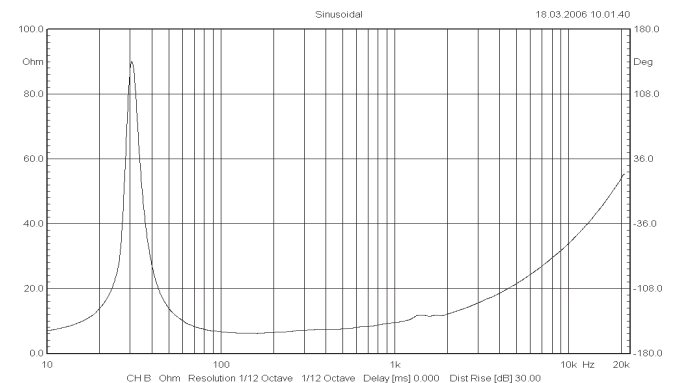

### Recommended reflex enclosure:

130L/38Hz, BRD=210mm/393mm long

Cone Drivers