



### Features:

- 96 dB sensitivity 1 W / 1 m
- 600 W power handling
- Extremely light weight of 4.1 kg
- 3" sandwich voice coil for low power compression
- Double treated cone for water protection
- Neodymium magnet
- Triple Aluminum demodulating rings for ultra low distortion
- Optimal for compact subwoofers

## SPECIFICATIONS

Application	Subwoofer	
Nominal impedance:	Ohm	4 or 8
Power handling AES noise:	W	600
Sensitivity (1 W / 1 m):	dB	96
Frequency response:	Hz	25 - 300
Voice coil diameter:	mm	77 (3")
Voice coil material:		Cu
Voice coil winding depth:	mm	26
Magnet gap depth:	mm	10
Basket:		Cast Aluminum
Effect. diaphragm diameter D	mm	252

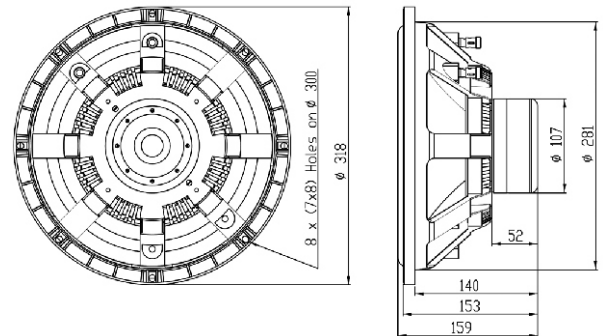

Frequency response measured 100 W (28.3 V) at 1 m in a closed enclosure of 50 liter incl. 2nd and 3rd harmonic distortion raised 20 dB.

THIELE-SMALL PARAMETERS			
Resonance frequency:	Fs	Hz	28.6
DC resistance:	Re	Ohm	6.00
Mechanical Q factor:	Qms		6.24
Electrical Q factor:	Qes		0.35
Total quality factor:	Qts		0.33
Equivalent volume:	Vas	l	85.5
Moving mass:	Mms	kg	0.127
Mechanical compl.:	Cms	mm / N	0.24
BL factor:	BL	Tesla m	19.8
Effective piston area:	Sd	m <sup>2</sup>	0.0498
Max. linear excursion:	Xmax	mm	± 8
Voice coil inductance:	Le1k	mH	0.68
	Le10k	mH	0.44

MOUNTING INFORMATION		
Overall diameter:	mm	318
Mounting holes diameter:	mm	8 x (7 x 8)
Bolt circle diameter:	mm	300
Baffle cut-out diameter:	mm	284
Overall depth:	mm	159
Net weight:	kg	4.1

### Recommended reflex enclosure:

44 l / 31 Hz, -3 dB = 35 Hz, BRD = 120 mm / 434 mm long  
 60 l / 27 Hz, -3 dB = 32 Hz, BRD = 110 mm / 517 mm long

